

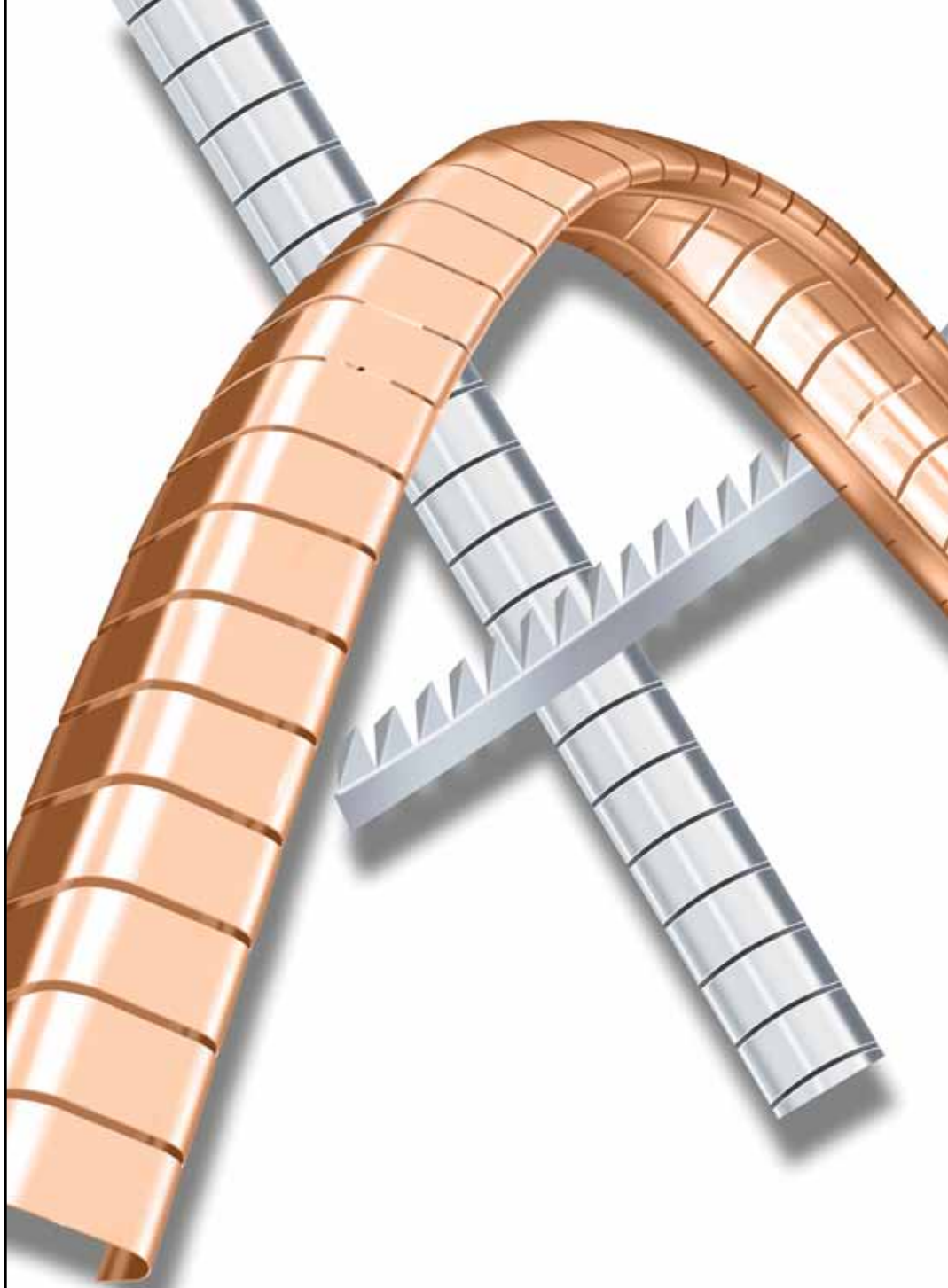

aerospace  
climate control  
electromechanical  
filtration  
fluid & gas handling  
hydraulics  
pneumatics  
process control  
sealing & shielding

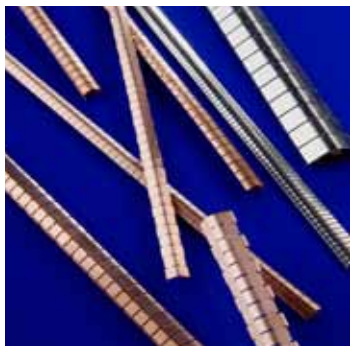

# Fingerstock Product Catalog

## Beryllium-Copper and Stainless Steel EMI Gaskets

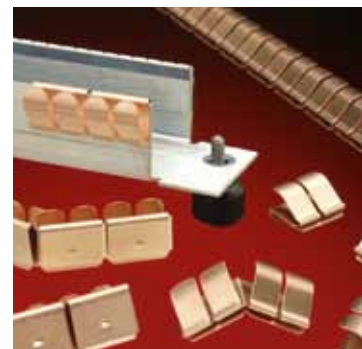

## CUSTOMER RESPONSIBILITY



### WARNING – USER RESPONSIBILITY

**FAILURE OR IMPROPER SELECTION OR IMPROPER USE OF THE PRODUCTS DESCRIBED HEREIN OR RELATED ITEMS CAN CAUSE DEATH, PERSONAL INJURY AND PROPERTY DAMAGE.**

- This document and other information from Parker-Hannifin Corporation, its subsidiaries and authorized distributors provide product or system options for further investigation by users having technical expertise.
- The user, through its own analysis and testing, is solely responsible for making the final selection of the system and components and assuring that all performance, endurance, maintenance, safety and warning requirements of the application are met. The user must analyze all aspects of the application, follow applicable industry standards, and follow the information concerning the product in the current product catalog and in any other materials provided from Parker or its subsidiaries or authorized distributors.
- To the extent that Parker or its subsidiaries or authorized distributors provide component or system options based upon data or specifications provided by the user, the user is responsible for determining that such data and specifications are suitable and sufficient for all applications and reasonably foreseeable uses of the components or systems.

## OFFER OF SALE

The items described in this document are hereby offered for sale by Parker Hannifin Corporation, its subsidiaries or its autho-

rized distributors. This offer and its acceptance are governed by the provisions stated in the detailed "Offer of Sale" elsewhere in this

document or available at [www.chomerics.com](http://www.chomerics.com) or [www.parker.com](http://www.parker.com).

## THERMAL MANAGEMENT & CONTROL

- Thermally conductive gap filler pads
- Dispensed thermal gap fillers
- Silicone-free thermal pads
- Phase-change materials (PCM)
- Polymer solder hybrids (PSH)
- Dispensable thermal compounds
- Thermal grease and gels
- Insulator pads
- Thin flexible heat spreaders
- Custom integrated thermal/EMI assemblies

## EMI SHIELDING & COMPLIANCE

- Conductive elastomers – molded, extruded, and form-in-place (FIP)
- Conductive foam based gaskets – fabric-over-foam and z-axis foam
- Conductive compounds – adhesives, sealants and caulks
- RF and thermal/RF absorbing materials
- EMI shielding plastics and injection molding services
- Coatings – direct metallization and conductive paints
- Metal gaskets – Springfingers, metal mesh and combination gaskets
- Foil laminates and conductive tapes
- EMI shielding vents – commercial and military honeycomb vents
- Shielded optical windows
- Cable shielding – ferrites and heat-shrink tubing/wire mesh tape/zippered cable shielding
- Compliance and safety test services

## OPTICAL DISPLAY PRODUCTS

- EMI shielding filters (conductive coating & wire mesh)
- Ant-reflective/contrast enhancement filters
- Plastic or glass laminations
- Hard coated lens protectors
- Touch screen lenses

## About Parker Hannifin Corporation

With annual sales exceeding \$10 billion, Parker Hannifin is the world's leading diversified manufacturer of motion and control technologies and systems, providing precision-engineered solutions for a wide variety of mobile, industrial and aerospace markets. The company's products are vital to virtually everything that moves or requires control, including the manufacture and processing of raw materials, durable goods, infrastructure development and all forms of transport. Traded on the New York Stock Exchange under the symbol "PH," Parker is strategically diversified, value-driven and well positioned for global growth as the industry consolidator and supplier of choice.

# Parker Chomerics Beryllium Copper and Stainless Steel Gaskets

Parker Chomerics beryllium-copper (BeCu) and stainless steel EMI gaskets (SPRING-LINE®) combine high levels of shielding effectiveness with a broad deflection range and low closure force properties. The spring finger wiping action can also help to reduce oxide build-up at mating contact surfaces when the gasket is used in applications demanding repeated openings and closings. The excellent performance qualities of beryllium-copper, including: high tensile strength, extreme operating temperature range and superb electrical conductivity, make it an ideal material for EMI shielding over a broad frequency range. For applications that are mechanically less demanding, stainless steel gaskets offer good tensile strength, extreme operating temperature range and good electrical conductivity. Stainless steel gaskets have higher compression set than BeCu, when used in demanding applications.

Our BeCu shielding gaskets are available in four Parker Chomerics standard finishes: clean and bright (unplated), zinc / clear trivalent chromate, bright nickel, and bright tin. These four finishes are RoHS compliant. Other common finishes are listed in Table 1 & 5 and are available upon request. BeCu gasket finishes should be chosen to minimize galvanic corrosion of the final assembly, see Table 3.

Stainless steel gaskets are only available with clean and bright (unplated) finishes. BeCu and Stainless steel gasket shielding effective properties are shown in Table 4.



## Galvanic Compatibility

Galvanic corrosion occurs as electrons move from dissimilar metals through an electrolyte, such as water or salt spray / fog. The goal of an EMI gasket is to be part of an electrically conductive shield and the gasket material is typically mated with a structural metal, such as aluminum or stainless steel. Since BeCu or stainless steel EMI gaskets are galvanically different than aluminum or steel, there would be two dissimilar metals in contact with each other. If the assembly in the application is susceptible to the presence of an electrolyte, there is a high probability that galvanic corrosion will occur, which will degrade both the structure and the shielding effectiveness in the application. To reduce the potential for corrosion, the electrical potential difference between the two metals should be minimized. This is where the availability of different finishes on BeCu

parts can help. For example, bright and clean BeCu parts in contact with chemically plated aluminum will typically corrode less if they are finished with tin plating. Nickel plated aluminum parts will work well with nickel plated BeCu. As an added bonus, among the current finishes we offer, nickel plating is also very abrasion resistant. Those applications with a lot of wear or many cycles could benefit from a nickel finish. Against zinc plated steel and zinc castings, the use of zinc/clear trivalent chromate parts is often used. See the Electromechanical Compatibility Table 3 on page 4 for further details.

For those applications where there is no concern for corrosion, such as those where there is no electrolyte present, then the risk for galvanic corrosion is minimal. In these applications a bright and clean (unplated) finish will suffice and save finish costs.

Material	Specification	Temperature Limit	
Beryllium Copper	ASTM B194 UNS C17200	-	
Stainless Steel	Type 301	-	
Non-Conductive Acrylic PSA (Shelf Life: 24 Months from Date of Manufacture)	3M F9469PC, 3M 9485PC, or equivalent	-40°F to +250°F (-40°C to +121°C)	
Plating/Finish	Finish Code (FFFF)	Specification	Thickness
Clean & Bright (Unplated)	-2000	N/A	N/A
Zinc/Clear Trivalent Chromate	-3000	Similar to ASTM B633	0.0001" (0.0025mm) min.
Bright Nickel	-4000	QQ-N-290, Class 2	0.0001" (0.0025mm) min.
Bright Tin (99%+ Tin)	-5000	ASTM B545	0.0001" (0.0025mm) min.
Satin (Matte) Tin	-5001	ASTM B545	0.0001" (0.0025mm) min.
Electroless Nickel	-6000	MIL-C-26074, Class 1	0.0001" (0.0025mm) min.
Silver	-7000	Similar to QQ-S-365, Type II, Grade A	0.0001" (0.0025mm) min.
Tin-Lead (60% / 40%)	-8000	ASTM B579	0.0001" (0.0025mm) min.
Gold	-9000	MIL-G-45204, Type II, Class 1, Grade C	0.00005" min. (0.0013mm) [Class 1]

# Ordering Procedure

Parker Chomerics has two part numbering systems for its fingerstock product line. Those part numbers beginning with **81-** and **5X-** are part of our fingerstock product family. (Part numbers beginning with 5X- are from an acquisition)

Please contact Chomerics for any help you may need or visit [www.chomerics.com](http://www.chomerics.com)

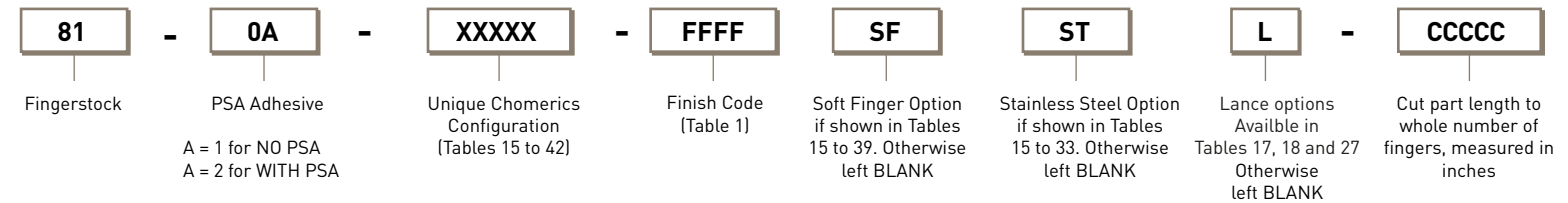

Part Number	Description
81-02-11818-2000	BeCu twist series fingerstock with PSA, configuration 11818, supplied with bright and clean finish, bulk format 16" long
81-02-11818-5000SF-00236	BeCu twist series fingerstock with PSA, configuration 11818, supplied with bright tin finish, Soft Finger 0.002" (0.05mm) thick, cut to 25 whole finger lengths, which equates to 2.36" cut length.
81-02-11818-2000ST-01139	Stainless steel twist series fingerstock with PSA, configuration 11818, supplied bright and clean (only option for stainless steel), cut to 120 whole finger lengths, which equates to 11.39" cut length.
81-01-14687-3000L-00141	BeCu edgemount twist series fingerstock with no PSA, configuration 14687, supplied with zinc/clear trivalent chromate finish, lance option, cut to 15 whole finger lengths, which equates to 1.41" cut length.
81-01-14623-4000L	BeCu edgemount fingerstock with no PSA, configuration 14623, supplied with bright nickel finish, lance option, bulk format 16" long.
81-01-14623-4000SFL	BeCu edgemount fingerstock with no PSA, configuration 14623, supplied with bright nickel finish, soft finger option, lance option, bulk format 16" long.
81-02-11817-5000-300	BeCu twist series fingerstock with PSA, configuration 11817, supplied with bright tin finish, 25 foot continuous coil which equates to 300" cut length.*

\* Note that the -300 suffix is an exception to the CCCCC part length code rule

## For Part numbers beginning with 5X-

When ordering standard Beryllium Copper Gaskets replace the second digit of the part number (X) with a 5. To order the low compression Soft finger version, change the "X" to a 6.

Example: 5X - 71000 = 55 - 71000 (Standard)  
56 - 71000 (Soft finger)

## T-LANCE AND D-LANCE

Items requiring a "T" or "D" lance, add a "T" or "D" on the end of the part number. Also, add the spacing dimension between lances: 500 for 1/2" or 100 for 1"

Example: For a "T" lance with 0.500" spacing --> 55-63000T500  
Example: For a "D" lance with 1.000" spacing --> 55-62000D100

## COILS

If BeCu coils are available, simply add the suffix code letter "C" to the part number.  
Example: 55-51500C

## PLATING

When ordering 5X- Beryllium Copper Gaskets with plating, refer to Table 5 below. Simply substitute the last two digits of the part number with the appropriate identification number of the plating to specified.

Example: 55 - 520 00 --> 55-520 06 (Satin Tin Finish)

Finish	Finish Code (FF)	Finish	Finish Code (FF)
Bright Finish	00	Dull Nickel	08
Gold	01	Electroless Nickel	09
Silver	02	Bright Nickel	10
Tin Lead	05	Zinc	12
Satin Tin	06	Zinc Chromate (Yellow)	13
Bright Tin	07	Zinc Chromate (Clear)	40

ANODE			
Group I	Group II	Group III	Group IV
Magnesium Alloys Aluminum Aluminum Alloys Zinc / Zinc Plating Chromium Plating Zinc / Zinc Plating Chromium Plating	Aluminum Aluminum Alloys Zinc & Zinc Plating Chromium Plating Cadmium Plating Carbon Steel Iron Nickel & Nickel Plating Tin & Tin Plating Tin / Lead Solder	Cadmium Plating Carbon Steel Iron Nickel & Nickel Plating Tin & Tin Plating Tin / Lead Solder Lead Brass Stainless Steel Beryllium Copper Copper / Copper Alloys Nickel / Copper Alloys	Brass Stainless Steel Beryllium Copper Copper / Copper Alloys Nickel / Copper Alloys Monel Silver Graphite Rhodium Titanium Platinum Gold
CATHODE			

Material	H-Field	E-Field	Plane Wave
25% deflection in accordance with MIL-STD-285 (modified) test procedure.			
Standard	100 kHz	10 MHz	1 GHz
Finger Stock	110 dB	100 dB	90 dB
Softstock	95dB	85dB	75dB

Shielding Effectiveness is typical. Customers should test for application specific concerns. Please contact Chomerics Test Services Lab for testing.

# Parker Chomerics Beryllium Copper and Stainless Steel Gaskets Selector Guide

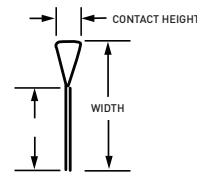

Table 6: Twist Series (See Tables 15-18 for Profiles)											
Designed for excellent bite through of surface finish, Twist Series has a wide range of compression applications with minimum flange heights and widths. Recommended deflection is minimum 20% up to 95% of the contact height. Available in coils and right angle design.	Attachment Method	Contact Height	Width	Finger Width		Pitch	Slot size	Minimum Material Thickness	Standard Lengths Available	Options Available	Materials Available
	Key Dimension Ranges					Inches (mm)					
	Clip-on*	0.030 (0.76)	0.150 (3.81)	0.080 (2.03)		0.095 (2.41)	0.015 (0.38)	0.002 (0.05)	16 (406.4) typical, select profiles available up to 24 (609.6)	Right Angle Clip-On Single Sided Double Sided Soft Finger (SF)	BeCu  Stainless Steel (ST)
	PSA**	0.210 (5.33)	0.270 (6.85)	0.485 (12.32)		0.500 (12.70)					

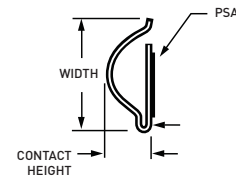

Table 7: General Purpose (Open End) (See Table 19-21 for Profiles)											
Low compression force strips with adhesive backing. General purpose contact strip offers superior performance under minimum compression. Recommended deflection is 20-60% of contact height. Ideally suited for applications requiring a range of compression due to variations in mounting surface. Wide range of sizes, some available in 25 ft coils.	Attachment Method	Contact Height	Width	Finger Width		Pitch	Slot size	Minimum Material Thickness	Standard Lengths Available	Options Available	Materials Available
	Key Dimension Ranges					Inches (mm)					
	PSA**	0.110 (2.79)	0.280 (7.11)	0.170 (4.31)		0.188 (4.77)	0.018 (0.46)	0.002 (0.05)	16 (406.4) typical, select profiles available up to 24 (609.6)	Select Profiles available in 25' (7.3m) coils	BeCu
		0.270 (6.85)	0.780 (19.81)	0.354 (8.99)		0.375 (9.52)	0.040 (1.01)				

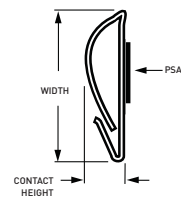

Table 8: Fold-Over (See Table 22 for Profiles)											
Same characteristics as the General Purpose series. However, this design incorporates a "fold over" feature which captures each finger, protecting them from damage. Recommended deflection is 20%-60% of contact height. Used in shielded doors, and has a contained footprint. Some profiles are available in 25 ft coils.	Attachment Method	Contact Height	Width	Finger Width		Pitch	Slot size	Minimum Material Thickness	Standard Lengths Available	Options Available	Materials Available
	Key Dimension Ranges					Inches (mm)					
	PSA**	0.080 (2.03)	0.250 (6.35)	0.170 (4.31)		0.188 (4.77)	0.015 (0.38)	0.002 (0.05)	16 (406.4) typical, select profiles available up to 24 (609.6)	Select Profiles available in 25' (7.3m) coils	BeCu
		0.280 (7.11)	0.760 (19.30)	0.354 (8.99)		0.375 (9.52)	0.032 (0.81)				

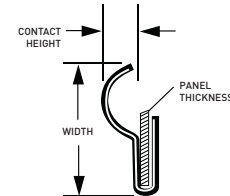

Table 9: Edge Mount (See Tables 23-28 for Profiles)											
For applications where adhesive mounting is not possible where space is limited. Operating temperature not limited by PSA. Panel thickness range is 0.030 (0.762) - 0.090 (2.286). Clip dimensions depicted can be modified to accommodate a variety of mounting surface thicknesses.	Attachment Method	Contact Height	Width	Finger Width		Pitch	Slot size	Minimum Material Thickness	Standard Lengths Available	Options Available	Materials Available
	Key Dimension Ranges					Inches (mm)					
	Clip on*	0.017 (0.43)	0.083 (2.10)	0.029 (0.73)		0.049 (1.24)	0.020 (0.51)	0.002 (0.05)	16 (406.4) typical, select profiles available up to 24 (609.6)	T-Lances available D-Lances available Custom clip radii available. No PSA option Reverse clip-ons available	BeCu
		0.270 (6.85)	1.090 (27.68)	0.341 (8.66)		0.380 (9.65)	0.047 (1.19)				

\*\* PSA width is typically 50% of contact area allowing for direct contact between gasket and substrate.

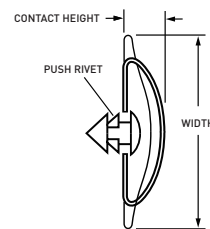
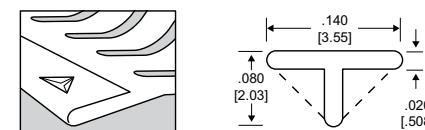

Table 10: Track & Rivet (See Tables 29 & 30 for Profiles)											
For bidirectional/shear closure force designs that require a highly reliable mounting method. Alternate rivet styles available.	Attachment Method	Contact Height	Width	Finger Width		Pitch	Slot size	Minimum Material Thickness	Standard Lengths Available	Options Available	Materials Available
	Key Dimension Ranges					Inches (mm)					
	Rivet	0.110 (2.79)	0.310 (7.87)	0.162 (4.11)		0.187 (4.74)	0.018 (0.45)	0.002 (0.05)	15 (381), 16.3 (414) (ST)	Available with center spine option.	BeCu Stainless Steel (ST)
		0.142 (3.60)	0.450 (11.43)	0.230 (5.84)		0.250 (6.35)	0.025 (0.63)				

<b>Finger Width Tolerance</b> +/- 0.005 (0.13)	<b>Pitch Tolerances</b> +/- 0.005 (0.13)
---	---

The user, through its own analysis and testing, is solely responsible for making the final selection of the system and components and assuring that all performance, endurance, maintenance, safety and warning requirements of the application are met. The user must analyze all aspects of the application, follow applicable industry standards, and follow the information concerning the product in the current product catalog and in any other materials provided from Parker or its subsidiaries or authorized distributors.

**\*T-LANCE** - Clip-on Gaskets with the "T" lance assure extra grip and electrical conductivity. "T" lance is the perfect solution for mounting gaskets on aluminum and other softer metals. All "T" lance gaskets are available in standard finishes.



**\*D-LANCE** - "D" lances snap into mounting surface holes for enhanced gripping power and conductivity. Standard lance locations are on 0.50 (12.70) centers. Other locations are available.

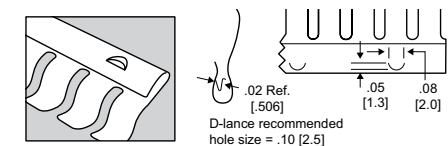

# Parker Chomerics Beryllium Copper and Stainless Steel Gaskets Selector Guide

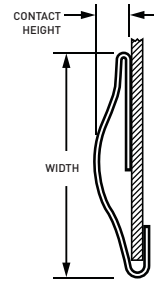

Table 11: Low Profile (See Tables 24, 28 & 33 for Profiles)												
	Attachment Method	Contact Height	Width	Finger Width		Pitch	Slot size	Minimum Material Thickness	Standard Lengths Available	Options Available	Materials Available	
For applications where gap height is limited and low closure force is required.	PSA** Hook on with PSA	Key Dimension Ranges					Inches (mm)		0.002 (0.05)	16" (406.4)	N/A	BeCu
		0.060 (1.52) 0.150 (3.81)	0.280 (7.11) 0.600 (15.24)	0.100 (2.54)		0.125 (3.17)	0.025 (0.63)					

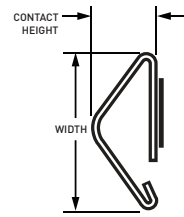

Table 12: No Snag (See Tables 31 - 35 for Profiles)												
	Attachment Method	Contact Height	Width	Finger Width		Pitch	Slot size	Minimum Material Thickness	Standard Lengths Available	Options Available	Materials Available	
Radius designed into sliding contact surface to eliminate leading sharp edges and enhanced conformance to substrate. This feature provides the additional benefit of increased handling safety. Single finger grounding clips available.	PSA**	Key Dimension Ranges					Inches (mm)		0.002 (0.05)	16 (406.4) typical, select profiles available up to 24 (609.6)	Soft Fingers Available Available with center spine option.	BeCu Stainless Steel (ST)
		0.080 (2.03) 0.400 (10.16)	0.210 (5.33) 1.100 (27.94)	0.042 (1.06) 0.460 (11.68)		0.060 (1.52) 0.500 (12.70)	0.018 (0.45) 0.040 (1.01)					

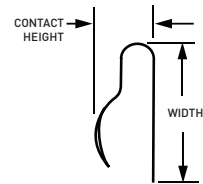

Table 13: Grounding Strips and Grounding Profiles (See Tables 41 & 42 for Profiles)												
	Attachment Method	Contact Height	Width	Finger Width		Pitch	Slot size	Minimum Material Thickness	Standard Lengths Available	Options Available	Materials Available	
For large enclosure applications such as large drawers and doors, like those used in shielded rooms. Some profiles available in 25-35ft coils.	Clip on*	Key Dimension Ranges					Inches (mm)		0.002 (0.05)	16 (406.4) typical, select profiles available up to 24 (609.6)	Grounding strips provided with spherical radiused fingers	BeCu
		0.080 (2.03) 0.410 (10.41)	0.520 (13.20) 1.670 (42.41)	0.141 (3.58) 0.460 (11.68)		0.188 (4.77) 0.375 (9.52)	0.040 (1.01) 0.047 (1.19)					

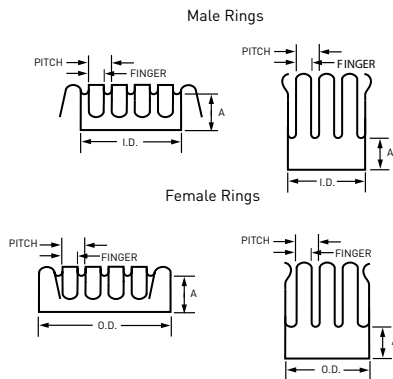
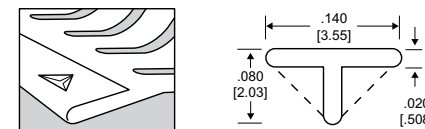

Table 14: Contact Rings												
	Attachment Method	Contact Height	Width	Finger Width		Pitch	Slot size	Minimum Material Thickness	Standard Lengths Available	Options Available	Materials Available	
Typically for cylindrical shaft applications. The shaft can be in static, linear, or rotating motion. Male and Female configurations available. Diameter is application specific.	Friction fit / Compression fit	Key Dimension Ranges					Inches (mm)		0.004 (0.10)	Diameter: Diameter is application specific	Male or female configurations available Diameters are application specific	BeCu
		0.040 (1.01) 0.440 (11.17)	0.340 (8.63) 0.890 (22.60)	0.040 (1.01) 0.140 (3.55)		0.060 (1.52) 0.187 (4.74)	0.020 (0.50) 0.062 (1.57)					

\*\* PSA width is typically 50% of contact area allowing for direct contact between gasket and substrate.

<b>Finger Width Tolerance</b> +/- 0.005 (0.13)	<b>Pitch Tolerances</b> +/- 0.005 (0.13)
---	---

**\*T-LANCE** - Clip-on Gaskets with the "T" lance assure extra grip and electrical conductivity. "T" lance is the perfect solution for mounting gaskets on aluminum and other softer metals. All "T" lance gaskets are available in standard finishes.



**\*D-LANCE** - "D" lances snap into mounting surface holes for enhanced gripping power and conductivity. Standard lance locations are on 0.50 (12.70) centers. Other locations are available.

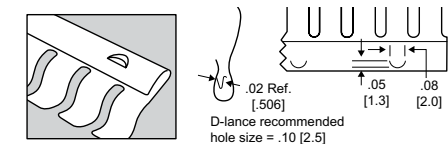

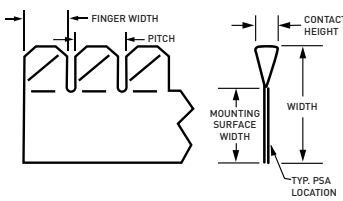

**Table 15: Twist Series**

Chomerics P/N	Contact Height	Width	Finger Width	Pitch	Material Thickness	Standard Length	Max length	Mounting Surface Width
81-02-14615-FFFF	0.030 (0.76)	0.200 (5.10)	0.080 (2.03)	0.095 (2.41)	0.003 (0.07)	16 (406)	24 (610)	0.140 (3.56)
81-02-11818-FFFF	0.030 (0.76)	0.230 (5.80)	0.080 (2.03)	0.095 (2.41)	0.003 (0.07)	16 (406)	Coil	0.140 (3.56)
81-02-11818-FFFFSF	0.030 (0.76)	0.230 (5.80)	0.080 (2.03)	0.095 (2.41)	0.002 (0.05)	16 (406)	Coil	0.140 (3.56)
81-02-11818-FFFFST	0.030 (0.76)	0.230 (5.80)	0.080 (2.03)	0.095 (2.41)	0.002 (0.05)	16 (406)	Coil	0.140 (3.56)
55-450FF	0.030 (0.76)	0.230 (5.80)	0.080 (2.03)	0.095 (2.41)	0.003 (0.07)	24 (610)	Coil	0.140 (3.56)
56-450FF	0.030 (0.76)	0.230 (5.80)	0.080 (2.03)	0.095 (2.41)	0.002 (0.05)	24 (610)	Coil	0.140 (3.56)
81-02-14616-FFFF	0.070 (1.78)	0.300 (7.60)	0.150 (3.81)	0.165 (4.19)	0.003 (0.07)	16 (406)	24 (610)	0.150 (3.81)
81-02-14616-FFFFSF	0.070 (1.78)	0.300 (7.60)	0.150 (3.81)	0.165 (4.19)	0.002 (0.05)	16 (406)	24 (610)	0.150 (3.81)
81-02-11817-FFFF	0.070 (1.78)	0.340 (8.64)	0.150 (3.81)	0.165 (4.19)	0.003 (0.07)	16 (406)	Coil	0.180 (4.57)
81-02-11817-FFFFSF	0.070 (1.78)	0.340 (8.64)	0.150 (3.81)	0.165 (4.19)	0.002 (0.05)	16 (406)	Coil	0.180 (4.57)
81-02-11817-FFFFST	0.070 (1.78)	0.340 (8.64)	0.150 (3.81)	0.165 (4.19)	0.002 (0.05)	16 (406)	Coil	0.180 (4.57)
81-02-14502-FFFF	0.070 (1.78)	0.470 (11.90)	0.150 (3.81)	0.165 (4.19)	0.003 (0.07)	16 (406)	24 (610)	0.310 (7.87)
55-455FF	0.070 (1.78)	0.340 (8.64)	0.150 (3.81)	0.165 (4.19)	0.003 (0.07)	24 (610)	Coil	0.190 (4.83)
81-02-11816-FFFF	0.070 (1.78)	0.340 (8.64)	0.150 (3.81)	0.165 (4.19)	0.003 (0.07)	24 (610)	Coil	0.190 (4.83)
55-460FF	0.070 (1.78)	0.500 (12.70)	0.150 (3.81)	0.165 (4.19)	0.003 (0.07)	24 (610)	Coil	0.200 (5.08)
56-455FF	0.070 (1.78)	0.340 (8.64)	0.150 (3.81)	0.165 (4.19)	0.002 (0.05)	24 (610)	Coil	0.190 (4.83)
56-460FF	0.070 (1.78)	0.500 (12.70)	0.150 (3.81)	0.165 (4.19)	0.002 (0.05)	24 (610)	Coil	0.200 (5.08)
81-02-14449-FFFF	0.120 (3.05)	0.500 (12.70)	0.235 (5.97)	0.250 (6.35)	0.003 (0.07)	16 (406)	25(7.57)	0.250 (6.35)
81-02-14450-FFFF	0.210 (5.33)	0.750 (19.05)	0.485 (12.32)	0.500 (12.70)	0.004 (0.10)	16 (406)	24 (610)	0.400 (10.16)

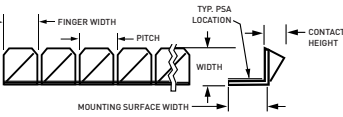
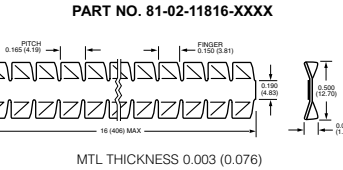

**Table 16: Right Angle Twist**

Chomerics P/N	Contact Height	Width	Finger Width	Pitch	Material Thickness	Standard Length	Max Length	Mounting Surface Width
55-651FF	0.030 (0.76)	0.080 (2.03)	0.080 (2.03)	0.095 (2.41)	0.003 (0.07)	24 (610)	24 (610)	0.160 (4.06)
56-651FF	0.030 (0.76)	0.080 (2.03)	0.080 (2.03)	0.095 (2.41)	0.002 (0.05)	24 (610)	24 (610)	0.160 (4.06)
81-02-14235-FFFF	0.030 (0.76)	0.090 (2.29)	0.080 (2.03)	0.095 (2.41)	0.003 (0.07)	16 (406)	24 (610)	0.140 (3.56)
81-02-14235-FFFFSF	0.030 (0.76)	0.090 (2.29)	0.080 (2.04)	0.095 (2.42)	0.002 (0.05)	16 (406)	24 (610)	0.140 (3.57)
81-02-14235-FFFFST	0.030 (0.76)	0.090 (2.29)	0.080 (2.05)	0.095 (2.43)	0.002 (0.05)	16 (406)	24 (610)	0.140 (3.58)
81-02-14347-FFFF	0.070 (1.78)	0.160 (4.06)	0.150 (3.81)	0.165 (4.19)	0.003 (0.07)	16 (406)	24 (610)	0.180 (4.57)
81-02-14347-FFFFSF	0.070 (1.78)	0.160 (4.06)	0.150 (3.81)	0.165 (4.19)	0.002 (0.05)	16 (406)	24 (610)	0.180 (4.57)
81-02-14347-FFFFST	0.070 (1.78)	0.160 (4.06)	0.150 (3.81)	0.165 (4.19)	0.002 (0.05)	16 (406)	24 (610)	0.180 (4.57)
55-655FF	0.070 (1.78)	0.160 (4.06)	0.150 (3.81)	0.165 (4.19)	0.003 (0.07)	24 (610)	24 (610)	0.190 (4.83)
56-655FF	0.070 (1.78)	0.160 (4.06)	0.150 (3.81)	0.165 (4.19)	0.002 (0.05)	24 (610)	24 (610)	0.190 (4.83)

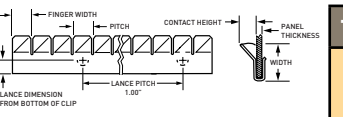

**Table 17: Twist Series Edge Mount**

Chomerics P/N	Contact Height	Width	Finger Width	Pitch	Material Thickness	Standard Length	Max Length	Panel Thickness	Lance Dimension From Bottom of clip
81-01-14493-FFFF	0.030 (0.76)	0.160 (4.06)	0.080 (2.03)	0.095 (2.41)	0.003 (0.07)	16 (406)	18 (457)	0.030 (0.76)	0.100 (2.54)
81-01-14685-FFFF	0.030 (0.76)	0.160 (4.06)	0.080 (2.03)	0.095 (2.41)	0.003 (0.07)	16 (406)	18 (457)	0.040 (1.02)	0.100 (2.54)
81-01-14507-FFFF	0.030 (0.76)	0.160 (4.06)	0.080 (2.03)	0.095 (2.41)	0.003 (0.07)	16 (406)	18 (457)	0.050 (1.27)	0.100 (2.54)
81-01-14399-FFFF	0.030 (0.76)	0.160 (4.06)	0.080 (2.03)	0.095 (2.41)	0.003 (0.07)	16 (406)	18 (457)	0.060 (1.52)	0.100 (2.54)
81-01-14456-FFFF	0.070 (1.78)	0.220 (5.59)	0.150 (3.81)	0.165 (4.19)	0.003 (0.07)	16 (406)	18 (457)	0.050 (1.27)	0.140 (3.56)
81-01-14457-FFFF	0.070 (1.78)	0.220 (5.59)	0.150 (3.81)	0.165 (4.19)	0.003 (0.07)	16 (406)	18 (457)	0.060 (1.52)	0.140 (3.56)

All Dimensions: inches (mm)

**Table 18: Twist Series Edge Mount**

Chomerics P/N	Contact Height	Width	Finger Width	Pitch	Material Thickness	Standard Length	Max Length	Panel Thickness	Lance Dimension From Bottom of Clip
81-01-14686-FFFF	0.030 (0.76)	0.230 (5.84)	0.080 (2.03)	0.095 (2.41)	0.003 (0.07)	16 (406)	18 (457)	0.030 (0.76)	0.100 (2.54)
81-01-14687-FFFF	0.030 (0.76)	0.230 (5.84)	0.080 (2.03)	0.095 (2.41)	0.003 (0.07)	16 (406)	18 (457)	0.040 (1.02)	0.100 (2.54)
81-01-14688-FFFF	0.030 (0.76)	0.230 (5.84)	0.080 (2.03)	0.095 (2.41)	0.003 (0.07)	16 (406)	18 (457)	0.060 (1.52)	0.100 (2.54)
55-652FF	0.030 (0.76)	0.150 (3.81)	0.080 (2.03)	0.095 (2.41)	0.003 (0.07)	24 (610)	24 (610)	0.060 (1.52)	--
56-652FF	0.030 (0.76)	0.150 (3.81)	0.080 (2.03)	0.095 (2.41)	0.002 (0.05)	24 (610)	24 (610)	0.060 (1.52)	--
81-01-14350-FFFF	0.070 (1.78)	0.380 (9.65)	0.150 (3.81)	0.165 (4.19)	0.003 (0.07)	16 (406)	24 (610)	0.060 (1.52)	0.140 (3.56)
55-665FF	0.070 (1.78)	0.270 (6.86)	0.150 (3.81)	0.165 (4.19)	0.003 (0.07)	24 (610)	24 (610)	0.060 (1.52)	--
56-665FF	0.070 (1.78)	0.270 (6.86)	0.150 (3.81)	0.165 (4.19)	0.002 (0.05)	24 (610)	24 (610)	0.060 (1.52)	--

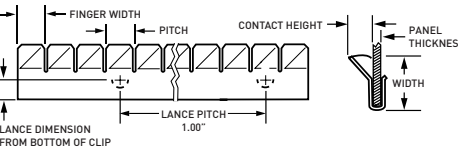

**Table 19: General Purpose - Open End**

Chomerics P/N	Contact Height	Width	Finger Width	Pitch	Material Thickness	Standard Length	Max Length
81-02-11826-FFFF	0.110 (2.80)	0.280 (7.11)	0.170 (4.32)	0.188 (4.76)	0.003 (0.07)	16 (406)	24 (610)
55-540FF	0.120 (3.05)	0.280 (7.11)	0.170 (4.32)	0.188 (4.76)	0.003 (0.08)	16 (406)	Coil
56-540FF	0.120 (3.05)	0.280 (7.11)	0.170 (4.32)	0.188 (4.76)	0.002 (0.05)	16 (406)	Coil
81-02-11825-FFFF	0.131 (3.32)	0.425 (10.80)	0.225 (5.75)	0.250 (6.35)	0.003 (0.07)	16 (406)	24 (610)
55-520FF	0.150 (3.81)	0.380 (9.65)	0.228 (5.79)	0.250 (6.35)	0.003 (0.08)	16 (406)	Coil
56-520FF	0.150 (3.81)	0.380 (9.65)	0.228 (5.79)	0.250 (6.35)	0.002 (0.05)	16 (406)	Coil
81-02-11824-FFFF	0.23 (5.85)	0.60 (15.25)	0.354 (9.00)	0.375 (9.50)	0.004 (0.10)	16 (406)	24 (610)
55-500FF	0.235 (5.97)	0.580 (14.73)	0.343 (8.71)	0.375 (9.50)	0.003 (0.08)	24 (610)	Coil
56-500FF	0.235 (5.97)	0.580 (14.73)	0.343 (8.71)	0.375 (9.50)	0.002 (0.05)	24 (610)	Coil
81-02-11823-FFFF	0.252 (6.40)	0.780 (19.80)	0.335 (8.50)	0.375 (9.50)	0.003 (0.07)	16 (406)	24 (610)
55-538FF	0.270 (6.86)	0.780 (19.80)	0.335 (8.50)	0.375 (9.50)	0.003 (0.08)	24 (610)	Coil
56-538FF	0.270 (6.86)	0.780 (19.80)	0.335 (8.50)	0.375 (9.50)	0.002 (0.05)	24 (610)	Coil

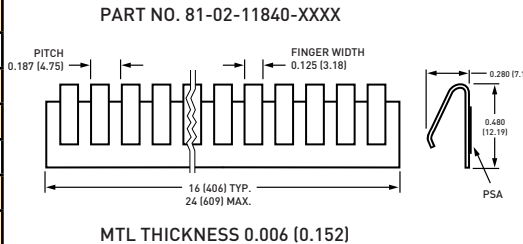
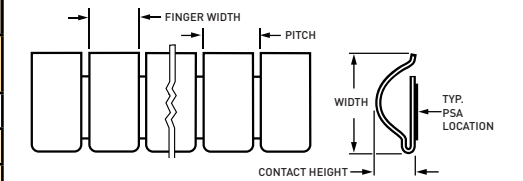

**Table 20: General Purpose - Low Profile**

Chomerics P/N	Contact Height	Width	Finger Width	Pitch	Material Thickness	Standard Length	Max Length
81-02-14312-FFFF	0.060 (1.52)	0.280 (7.11)	0.100 (2.54)	0.125 (3.18)	0.002 (0.05)	16 (406)	16.0 (406)
81-02-15030-FFFF	0.080 (2.03)	0.320 (8.13)	0.100 (2.54)	0.125 (3.18)	0.002 (0.05)	16 (406)	16.0 (406)

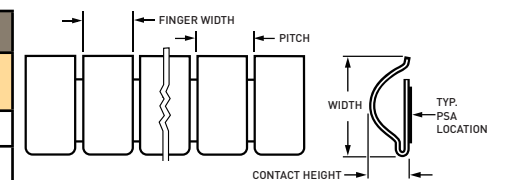

**Table 21: General Purpose - Large Enclosures**

Chomerics P/N	Contact Height	Width	Finger Width	Pitch	Material Thickness	Standard Length	Max Length	Hole Width From Edge	Attachment Hole Opening Diameter
55-63800	0.230 (5.84)	1.090 (27.69)	0.335 (8.51)	0.375 (9.50)	0.004 (0.10)	24 (610)	25 ft(7.57m)	0.157 (3.99)	0.140 (3.56)
55-63900	0.230 (5.84)	1.500 (38.1)	0.335 (8.51)	0.375 (9.50)	0.004 (0.10)	24 (610)	25 ft(7.57m)	0.567 (14.40)	0.140 (3.56)
56-63800	0.230 (5.84)	1.090 (27.69)	0.335 (8.51)	0.375 (9.50)	0.002 (0.05)	24 (610)	25 ft(7.57m)	0.157 (3.99)	0.140 (3.56)
56-63900	0.230 (5.84)	1.500 (38.1)	0.335 (8.51)	0.375 (9.50)	0.002 (0.05)	24 (610)	25 ft(7.57m)	0.567 (14.40)	0.140 (3.56)
81-01-11901-FFFF	0.260 (6.60)	1.090 (27.69)	0.343 (8.70)	0.375 (9.50)	0.004 (0.10)	16 (406)	35ft. (10.7m)	0.154 (3.90)	0.138 (3.50)
81-01-14339-FFFF	0.410 (10.41)	1.670 (42.42)	0.460 (11.68)	0.500 (12.70)	0.007 (0.178)	16 (406)	35ft. (10.7m)	0.19 (4.83)	0.140 (3.56)

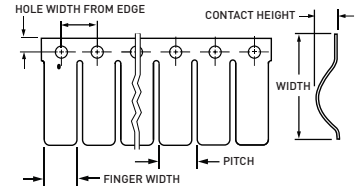

**Finger Width Tolerance**  
+/- 0.005 (0.13)

**Pitch Tolerances**  
+/- 0.005 (0.13)

**Coil Length = 25 Feet (7.57 Meters)**

# Parker Chomerics Beryllium Copper and Stainless Steel Gaskets

# Part Number and Detail Index (Sorted by Contact Height and then by Width)

All Dimensions: inches (mm)

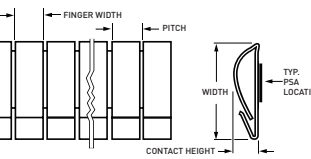

Chomerics P/N	Contact Height	Width	Finger Width	Pitch	Material Thickness	Standard Length	Max Length
55-541FF	0.120 (3.04)	0.380 (9.65)	0.335 (8.50)	0.188 (4.76)	0.003 (0.08)	16 (406)	Coil
56-541FF	0.120 (3.04)	0.380 (9.65)	0.335 (8.50)	0.188 (4.76)	0.002 (0.05)	16 (406)	Coil
55-542FF	0.080 (2.32)	0.250 (6.35)	0.170 (4.32)	0.188 (4.76)	0.003 (0.08)	16 (406)	Coil
56-542FF	0.080 (2.32)	0.250 (6.35)	0.170 (4.32)	0.188 (4.76)	0.002 (0.05)	16 (406)	Coil
81-02-11838-FFFF	0.122 (3.10)	0.382 (9.70)	0.175 (4.45)	0.190 (4.83)	0.003 (0.07)	16 (406)	24 (610)
81-02-11837-FFFF	0.142 (3.60)	0.500 (12.70)	0.228 (5.79)	0.250 (6.35)	0.003 (0.07)	16 (406)	24 (610)
55-521FF	0.150 (3.81)	0.510 (12.95)	0.228 (5.79)	0.250 (6.35)	0.003 (0.08)	16 (406)	Coil
56-521FF	0.150 (3.81)	0.510 (12.95)	0.228 (5.79)	0.250 (6.35)	0.002 (0.05)	16 (406)	Coil
81-02-11836-FFFF	0.220 (5.60)	0.760 (19.30)	0.354 (9.00)	0.375 (9.53)	0.003 (0.07)	16 (406)	24 (610)
55-515FF	0.230 (5.84)	0.760 (19.30)	0.343 (8.71)	0.375 (9.50)	0.003 (0.08)	24 (610)	25 (7.57)
56-515FF	0.230 (5.84)	0.760 (19.30)	0.343 (8.71)	0.375 (9.50)	0.002 (0.05)	24 (610)	Coil

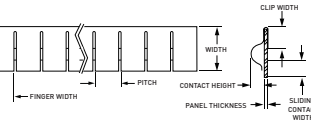

Chomerics P/N	Contact Height	Width	Finger Width	Pitch	Material Thickness	Standard Length	Max Length	Panel Thickness	Clip Width	Sliding Contact Width
81-01-14403-FFFF	0.120 (3.05)	0.420 (10.67)	0.225 (5.72)	0.250 (6.35)	0.003 (0.08)	16 (406)	16 (406)	0.030 (0.76)	0.210 (5.33)	0.090 (2.29)
81-01-14403-FFFFSF	0.120 (3.05)	0.420 (10.67)	0.225 (5.72)	0.250 (6.35)	0.002 (0.06)	16 (406)	16 (406)	0.030 (0.76)	0.210 (5.33)	0.090 (2.29)
81-01-14404-FFFF	0.120 (3.05)	0.420 (10.67)	0.225 (5.72)	0.250 (6.35)	0.003 (0.08)	16 (406)	16 (406)	0.060 (1.52)	0.210 (5.33)	0.090 (2.29)
81-01-14404-FFFFSF	0.120 (3.05)	0.420 (10.67)	0.225 (5.72)	0.250 (6.35)	0.002 (0.06)	16 (406)	16 (406)	0.060 (1.52)	0.210 (5.33)	0.090 (2.29)

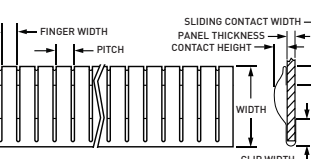

Chomerics P/N	Contact Height	Width	Finger Width	Pitch	Material Thickness	Standard Length	Max Length	Panel Thickness	Clip Width	Sliding Contact Width
81-01-14453-FFFF	0.080 (2.03)	0.550 (13.97)	0.100 (2.54)	0.125 (3.18)	0.003 (0.08)	16 (406)	16 (406)	0.060 (1.52)	0.19 (4.83)	0.130 (3.30)
81-01-14453-FFFFSF	0.080 (2.03)	0.550 (13.97)	0.100 (2.54)	0.125 (3.18)	0.002 (0.06)	16 (406)	16 (406)	0.060 (1.52)	0.19 (4.83)	0.130 (3.30)
81-01-14454-FFFF	0.120 (3.05)	0.750 (19.05)	0.100 (2.54)	0.125 (3.18)	0.003 (0.08)	16 (406)	16 (406)	0.060 (1.52)	0.18 (4.57)	0.17 (4.32)
81-01-14454-FFFFSF	0.120 (3.05)	0.750 (19.05)	0.100 (2.54)	0.125 (3.18)	0.002 (0.06)	16 (406)	16 (406)	0.060 (1.52)	0.18 (4.57)	0.17 (4.32)

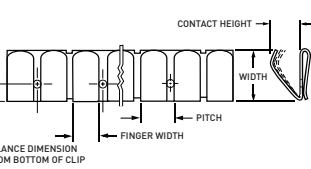

Chomerics P/N	Contact Height	Width	Finger Width	Pitch	Material Thickness	Standard Length	Max Length	Panel Thickness	Lance Dimension from fold of clip
81-01-11827-FFFF	0.200 (5.08)	0.375 (9.53)	0.211 (5.35)	0.250 (6.35)	0.005 (0.12)	16 (406)	24 (610)	0.040 (1.02)	0.160 (4.06)
55-650FF	0.200 (5.08)	0.380 (9.65)	0.210 (5.33)	0.250 (6.35)	0.005 (0.12)	16 (406)	24 (610)	.05-.07(1.27-1.78)	0.100 (2.54)
55-660FF	0.200 (5.08)	0.380 (9.65)	0.210 (5.33)	0.250 (6.35)	0.005 (0.12)	16 (406)	24 (610)	.05-.07(1.27-1.78)	0.130 (3.30)
56-650FF	0.200 (5.08)	0.380 (9.65)	0.210 (5.33)	0.250 (6.35)	0.002 (0.05)	16 (406)	24 (610)	.05-.07(1.27-1.78)	0.100 (2.54)
56-660FF	0.200 (5.08)	0.380 (9.65)	0.210 (5.33)	0.250 (6.35)	0.002 (0.05)	16 (406)	24 (610)	.05-.07(1.27-1.78)	0.130 (3.30)
81-01-14323-FFFF	0.270 (6.86)	0.370 (9.40)	0.210 (5.33)	0.250 (6.35)	0.005 (0.12)	16 (406)	24 (610)	0.060 (1.52)	0.130 (3.30)

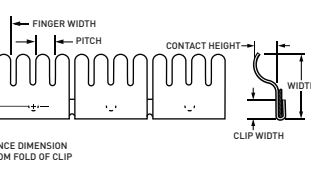

Chomerics P/N	Contact Height	Width	Finger Width	Pitch	Material Thickness	Standard Length	Max Length	Panel Thickness	Clip Width	Lance Dimension From Fold of Clip
55-666FF	0.165 (4.19)	0.600 (15.24)	0.141 (3.58)	0.187 (4.75)	0.005 (0.12)	16 (406)	16 (406)	.090(2.29)	.19(4.83)	-
56-666FF	0.165 (4.19)	0.600 (15.24)	0.141 (3.58)	0.187 (4.75)	0.002 (0.05)	16 (406)	16 (406)	.090(2.29)	.19(4.83)	-
55-667FF	0.200 (5.08)	0.272 (6.90)	0.160 (4.06)	0.190 (4.83)	0.003 (0.08)	18 (457)	18 (457)	0.060 (1.52)	.239(6.07)	-
56-667FF	0.200 (5.08)	0.272 (6.90)	0.160 (4.06)	0.190 (4.83)	0.002 (0.05)	18 (457)	18 (457)	0.060 (1.52)	.239(6.07)	-
81-01-14340-FFFF	0.210 (5.33)	0.600 (15.24)	0.135 (3.43)	0.182 (4.62)	0.005 (0.12)	16 (406)	16 (406)	0.040 (1.02)	-	0.140 (3.56)
81-01-14332-FFFF	0.210 (5.33)	0.600 (15.24)	0.135 (3.43)	0.182 (4.62)	0.005 (0.12)	16 (406)	16 (406)	0.060 (1.52)	-	0.130 (3.30)

Chomerics P/N	Contact Height	Width	Finger Width	Pitch	Material Thickness	Standard Length	Max Length	Panel Thickness
55-620FF	0.078 (1.98)	0.440 (11.17)	0.141 (3.58)	0.188 (4.78)	0.004 (0.10)	16 (406)	16 (406)	0.060 (1.52)
56-620FF	0.078 (1.98)	0.440 (11.17)	0.141 (3.58)	0.188 (4.78)	0.002 (0.05)	16 (406)	16 (406)	0.060 (1.52)
81-01-14411-FFFF	0.080 (2.03)	0.420 (10.67)	0.140 (3.56)	0.187 (4.75)	0.005 (0.12)	16 (406)	16 (406)	0.040 (1.02)
81-01-14381-FFFF	0.080 (2.03)	0.420 (10.67)	0.140 (3.56)	0.187 (4.75)	0.005 (0.12)	16 (406)	16 (406)	0.050 (1.27)
81-01-14383-FFFF	0.080 (2.03)	0.420 (10.67)	0.140 (3.56)	0.187 (4.75)	0.005 (0.12)	16 (406)	16 (406)	0.060 (1.52)
55-610FF	0.092 (2.33)	0.300 (7.62)	0.141 (3.58)	0.188 (4.78)	0.004 (0.10)	16 (406)	16 (406)	0.060 (1.52)
56-610FF	0.092 (2.33)	0.300 (7.62)	0.141 (3.58)	0.188 (4.78)	0.002 (0.05)	16 (406)	16 (406)	0.060 (1.52)
81-01-14617-FFFF	0.100 (2.54)	0.300 (7.62)	0.140 (3.56)	0.187 (4.75)	0.005 (0.12)	16 (406)	16 (406)	0.045 (1.14)
81-01-14618-FFFF	0.100 (2.54)	0.300 (7.62)	0.140 (3.56)	0.187 (4.75)	0.005 (0.12)	16 (406)	16 (406)	0.050 (1.27)
81-01-14619-FFFF	0.100 (2.54)	0.300 (7.62)	0.140 (3.56)	0.187 (4.75)	0.005 (0.12)	16 (406)	16 (406)	0.065 (1.65)
81-01-14620-FFFF	0.100 (2.54)	0.300 (7.62)	0.140 (3.56)	0.187 (4.75)	0.005 (0.12)	16 (406)	16 (406)	0.070 (1.48)
81-01-14624-FFFF	0.110 (2.79)	0.450 (11.43)	0.140 (3.56)	0.187 (4.75)	0.005 (0.12)	16 (406)	16 (406)	0.045 (1.14)
81-01-14625-FFFF	0.110 (2.79)	0.450 (11.43)	0.140 (3.56)	0.187 (4.75)	0.005 (0.12)	16 (406)	16 (406)	0.050 (1.27)
81-01-14626-FFFF	0.110 (2.79)	0.450 (11.43)	0.140 (3.56)	0.187 (4.75)	0.005 (0.12)	16 (406)	16 (406)	0.065 (1.65)
81-01-14627-FFFF	0.110 (2.79)	0.450 (11.43)	0.140 (3.56)	0.187 (4.75)	0.005 (0.12)	16 (406)	16 (406)	0.070 (1.48)
81-01-14623-FFFF	0.120 (3.05)	0.420 (10.67)	0.140 (3.56)	0.187 (4.75)	0.005 (0.12)	16 (406)	16 (406)	0.040 (1.02)
81-01-14623-FFFFSF	0.120 (3.05)	0.420 (10.67)	0.140 (3.56)	0.187 (4.75)	0.003 (0.08)	16 (406)	16 (406)	0.040 (1.02)
81-01-14351-FFFF	0.120 (3.05)	0.420 (10.67)	0.140 (3.56)	0.187 (4.75)	0.005 (0.12)	16 (406)	16 (406)	0.060 (1.52)
81-01-14351-FFFFSF	0.120 (3.05)	0.420 (10.67)	0.140 (3.56)	0.187 (4.75)	0.003 (0.08)	16 (406)	16 (406)	0.060 (1.52)
81-01-14410-FFFF	0.120 (3.05)	0.420 (10.67)	0.140 (3.56)	0.187 (4.75)	0.005 (0.12)	16 (406)	16 (406)	0.090 (2.29)
81-01-14410-FFFFSF	0.120 (3.05)	0.420 (10.67)	0.140 (3.56)	0.187 (4.75)	0.003 (0.08)	16 (406)	16 (406)	0.090 (2.29)
81-01-14621-FFFF	0.140 (3.56)	0.420 (10.67)	0.140 (3.56)	0.187 (4.75)	0.005 (0.12)	16 (406)	16 (406)	0.030 (0.76)
81-01-14621-FFFFSF	0.140 (3.56)	0.420 (10.67)	0.140 (3.56)	0.187 (4.75)	0.003 (0.08)	16 (406)	16 (406)	0.030 (0.76)
81-01-14341-FFFF	0.140 (3.56)	0.420 (10.67)	0.140 (3.56)	0.187 (4.75)	0.005 (0.12)	16 (406)	16 (406)	0.050 (1.27)
81-01-14341-FFFFSF	0.140 (3.56)	0.420 (10.67)	0.140 (3.56)	0.187 (4.75)	0.003 (0.08)	16 (406)	16 (406)	0.050 (1.27)
81-01-14498-FFFF	0.140 (3.56)	0.420 (10.67)	0.140 (3.56)	0.187 (4.75)	0.005 (0.12)	16 (406)	16 (406)	0.060 (1.52)
81-01-14498-FFFFSF	0.140 (3.56)	0.420 (10.67)	0.140 (3.56)	0.187 (4.75)	0.003 (0.08)	16 (406)	16 (406)	0.060 (1.52)
81-01-14622-FFFF	0.160 (4.06)	0.420 (10.67)	0.140 (3.56)	0.187 (4.75)	0.005 (0.12)	16 (406)	16 (406)	0.060 (1.52)
81-01-14622-FFFFSF	0.160 (4.06)	0.420 (10.67)	0.140 (3.56)	0.187 (4.75)	0.003 (0.08)	16 (406)	16 (406)	0.060 (1.52)
55-630FF	0.205 (5.20)	0.600 (15.24)	0.141 (3.58)	0.188 (4.78)	0.004 (0.10)	16 (406)	16 (406)	0.060 (1.52)
56-630FF	0.205 (5.20)	0.600 (15.24)	0.141 (3.58)	0.188 (4.78)	0.002 (0.05)	16 (406)	16 (406)	0.060 (1.52)
55-640FF	0.255 (6.48)	1.090 (2.77)	0.335 (8.51)	0.375 (9.52)	0.004 (0.10)	16 (406)	16 (406)	0.070 (1.48)
56-640FF	0.255 (6.48)	1.090 (2.77)	0.335 (8.51)	0.375 (9.52)	0.002 (0.05)	16 (406)	16 (406)	0.070 (1.48)

\*Lances optional on all profiles below. Add L to the end of the part number (i.e. 81-01-14411-2000L)

Chomerics P/N	Contact Height	Width	Finger Width	Pitch	Material Thickness	Standard Length	Max Length	Max. Panel Thickness	Mounting Surface Width	Sliding Hook Width
81-02-14274-FFFF	0.060 (1.52)	0.450 (11.43)	0.100 (2.54)	0.125 (3.18)	0.003 (0.08)	16 (406)	16 (406)	0.060 (1.02)	0.240 (6.10)	0.100 (2.54)
81-02-14274-FFFFSF	0.060 (1.52)	0.450 (11.43)	0.100 (2.54)	0.125 (3.18)	0.002 (0.06)	16 (406)	16 (406)	0.060 (1.02)	0.240 (6.10)	0.100 (2.54)
81-02-14274-FFFFST	0.060 (1.52)	0.450 (11.43)	0.100 (2.54)	0.125 (3.18)	0.002 (0.05)	16 (406)	16 (406)	0.060 (1.02)	0.240 (6.10)	0.100 (2.54)
81-02-14368-FFFF	0.090 (2.29)	0.600 (15.24)	0.100 (2.54)	0.125 (3.18)	0.003 (0.08)	16 (406)	16 (406)	0.060 (1.02)	0.320 (8.13)	0.140 (3.56)
81-02-14368-FFFFSF	0.090 (2.29)	0.600 (15.24)	0.100 (2.54)	0.125 (3.18)	0.002 (0.06)	16 (406)	16 (406)	0.060 (1.02)	0.320 (8.13)	0.140 (3.56)
81-02-14368-FFFFST	0.090 (2.29)	0.600 (15.24)	0.100 (2.54)	0.125 (3.18)	0.002 (0.05)	16 (406)	16 (406)	0.060 (1.02)	0.320 (8.13)	0.140 (3.56)
81-02-14452-FFFF	0.140 (3.56)	0.550 (13.97)	0.100 (2.54)	0.125 (3.18)	0.003 (0.08)	16 (406)	16 (406)	0.060 (1.02)	0.320 (8.13)	0.140 (3.56)
81-02-14452-FFFFSF	0.140 (3.56)	0.550 (13.97)	0.100 (2.54)	0.125 (3.18)	0.002 (0.06)	16 (406)	16 (406)	0.060 (1.02)	0.320 (8.13)	0.140 (3.56)

Finger Width Tolerance +/- 0.005 (0.13)  
Pitch Tolerances +/- 0.005 (0.13)  
Coil Length = 25 Feet (7.57 Meters)

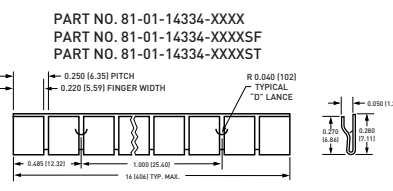
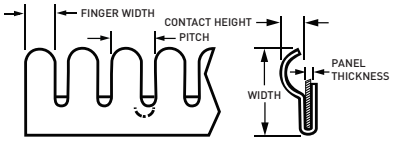

MTL THICKNESS 0.006 (0.152)  
SF (SOFT FINGERS) MTL THICKNESS 0.0035 (0.089)  
ST (STAINLESS STEEL) MTL THICKNESS 0.004 (0.102)



All Dimensions: inches (mm)

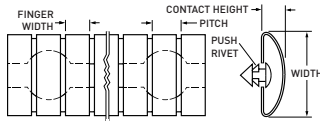

Chomerics P/N	Contact Height	Width	Finger Width	Pitch	Material Thickness	Standard Length	Max Length	Minimum Gap
*81-01-11833-FFFF	0.110 (2.80)	0.350 (8.90)	0.169 (4.30)	0.187 (4.75)	0.003 (0.07)	15 (381)	15 (381)	0.070 (1.78)
55-551FF	0.110 (2.80)	0.350 (8.90)	0.170 (4.32)	0.187 (4.78)	0.003 (0.07)	15 (381)	15 (381)	0.070 (1.78)
55-552FF	0.110 (2.80)	0.350 (8.90)	0.170 (4.32)	0.187 (4.78)	0.003 (0.07)	15 (381)	15 (381)	0.070 (1.78)
55-553FF	0.110 (2.80)	0.350 (8.90)	0.170 (4.32)	0.187 (4.78)	0.003 (0.07)	15 (381)	15 (381)	0.070 (1.78)
55-558FF	0.110 (2.80)	0.350 (8.90)	0.170 (4.32)	0.187 (4.78)	0.003 (0.07)	15 (381)	15 (381)	0.070 (1.78)
55-559FF	0.110 (2.80)	0.350 (8.90)	0.170 (4.32)	0.187 (4.78)	0.003 (0.07)	15 (381)	15 (381)	0.070 (1.78)
56-551FF	0.110 (2.80)	0.350 (8.90)	0.170 (4.32)	0.187 (4.78)	0.002 (0.05)	15 (381)	15 (381)	0.070 (1.78)
56-552FF	0.110 (2.80)	0.350 (8.90)	0.170 (4.32)	0.187 (4.78)	0.002 (0.05)	15 (381)	15 (381)	0.070 (1.78)
56-553FF	0.110 (2.80)	0.350 (8.90)	0.170 (4.32)	0.187 (4.78)	0.002 (0.05)	15 (381)	15 (381)	0.070 (1.78)
56-558FF	0.110 (2.80)	0.350 (8.90)	0.170 (4.32)	0.187 (4.78)	0.002 (0.05)	15 (381)	15 (381)	0.070 (1.78)
56-559FF	0.110 (2.80)	0.350 (8.90)	0.170 (4.32)	0.187 (4.78)	0.002 (0.05)	15 (381)	15 (381)	0.070 (1.78)
*81-01-11832-FFFF	0.140 (3.60)	0.410 (10.41)	0.230 (5.84)	0.250 (6.35)	0.003 (0.07)	15 (381)	15 (381)	0.080 (2.03)
55-555FF	0.140 (3.60)	0.450 (11.43)	0.228 (5.79)	0.250 (6.35)	0.003 (0.07)	15 (381)	15 (381)	0.080 (2.03)
55-556FF	0.140 (3.60)	0.450 (11.43)	0.228 (5.79)	0.250 (6.35)	0.003 (0.07)	15 (381)	15 (381)	0.080 (2.03)
56-555FF	0.140 (3.60)	0.450 (11.43)	0.228 (5.79)	0.250 (6.35)	0.002 (0.05)	15 (381)	15 (381)	0.080 (2.03)
56-556FF	0.140 (3.60)	0.450 (11.43)	0.228 (5.79)	0.250 (6.35)	0.002 (0.05)	15 (381)	15 (381)	0.080 (2.03)

\*Provided fully assembled with Brass Alloy CZ108 Track and Plastic Push Rivets  
 \*\* Typical Dimension, actual may vary with application

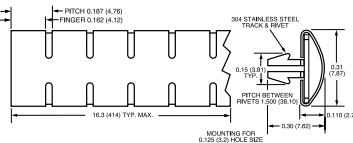

Chomerics P/N	Contact Height	Width	Finger Width	Pitch	Material Thickness	Standard Length	Max Length	Minimum Gap
81-01-14552-FFFF	0.110 (2.79)	0.310 (7.87)	0.162 (4.12)	0.187 (4.76)	0.002 (0.05)	16.3 (414)	16.3 (414)	0.070 (1.78)

\*\*Provided fully assembled onto 304 Stainless Steel Track

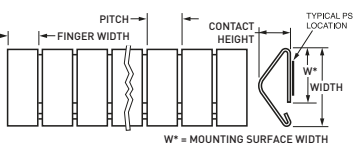

Chomerics P/N	Contact Height	Width	Finger Width	Pitch	Material Thickness	Standard Length	Max Length	Mounting Surface Width
*81-02-14455-FFFF	0.080 (2.03)	0.210 (5.33)	0.042 (1.07)	0.060 (1.52)	0.002 (0.05)	16 (406)	16 (406)	0.130 (3.30)
*81-02-14310-FFFF	0.080 (2.03)	0.210 (5.33)	0.169 (4.29)	0.187 (4.75)	0.002 (0.05)	16 (406)	16 (406)	0.130 (3.30)
*81-02-14310-FFFFST	0.080 (2.03)	0.210 (5.33)	0.169 (4.29)	0.187 (4.75)	0.002 (0.05)	16 (406)	16 (406)	0.130 (3.30)
81-02-14311-FFFF	0.110 (2.79)	0.280 (7.11)	0.169 (4.29)	0.187 (4.75)	0.002 (0.05)	16 (406)	24 (610)	0.180 (4.57)
81-02-14294-FFFF	0.110 (2.79)	0.320 (8.13)	0.169 (4.29)	0.187 (4.75)	0.002 (0.05)	16 (406)	18 (457)	0.210 (5.33)
81-02-11819-FFFF	0.110 (2.79)	0.320 (8.13)	0.169 (4.29)	0.187 (4.75)	0.004 (0.10)	16 (406)	16 (406)	0.210 (5.33)
81-02-14306-FFFF	0.130 (3.30)	0.370 (9.40)	0.225 (5.72)	0.250 (6.35)	0.002 (0.05)	16 (406)	16 (406)	0.210 (5.33)
*81-02-14200-FFFF	0.130 (3.30)	0.370 (9.40)	0.225 (5.72)	0.250 (6.35)	0.002 (0.05)	16 (406)	16 (406)	0.210 (5.33)
81-02-14337-FFFF	0.220 (5.59)	0.600 (15.24)	0.343 (8.71)	0.375 (9.53)	0.003 (0.08)	16 (406)	24 (610)	0.280 (7.11)
81-02-14337-FFFFSF	0.220 (5.59)	0.600 (15.24)	0.343 (8.71)	0.375 (9.53)	0.002 (0.05)	16 (406)	24 (610)	0.280 (7.11)
81-02-11820-FFFF	0.220 (5.59)	0.610 (15.40)	0.343 (8.71)	0.375 (9.53)	0.004 (0.10)	16 (406)	16 (406)	0.280 (7.11)
81-02-14432-FFFF	0.320 (8.13)	0.800 (20.32)	0.343 (8.71)	0.375 (9.53)	0.004 (0.10)	16 (406)	24 (610)	0.440 (11.18)
81-02-14461-FFFF	0.400 (10.16)	1.100 (27.94)	0.460 (11.68)	0.480 (12.19)	0.005 (0.12)	16 (406)	24 (610)	0.780 (19.81)
81-02-14315-FFFF	0.400 (10.16)	1.100 (27.94)	0.460 (11.68)	0.500 (12.70)	0.005 (0.12)	16 (406)	18 (457)	0.780 (19.81)

\*Provided with an extended PSA release liner

Chomerics P/N	Contact Height	Width	Finger Width	Pitch	Material Thickness	Standard Length	Max Length
81-02-15031-FFFF	0.080 (2.03)	0.350 (8.89)	0.100 (2.54)	0.125 (3.18)	0.002 (0.05)	16 (406)	16 (406)
55-557FF	0.110 (2.80)	0.350 (8.89)	0.170 (4.32)	0.187 (4.78)	0.003 (0.07)	15 (381)	15 (381)
56-557FF	0.110 (2.80)	0.350 (8.89)	0.170 (4.32)	0.187 (4.78)	0.002 (0.05)	15 (381)	15 (381)
81-02-11834-FFFF	0.118 (3.00)	0.350 (8.89)	0.169 (4.29)	0.187 (4.75)	0.003 (0.07)	16 (406)	20 (508)
81-02-14467-FFFF	0.120 (3.00)	0.350 (8.89)	0.169 (4.29)	0.187 (4.75)	0.003 (0.07)	*0.92 (23.4)	0.92 (23.4)
56-700FF	0.130 (3.30)	0.370 (9.40)	0.225 (5.72)	0.250 (6.35)	0.002 (0.05)	15 (381)	15 (381)
55-554FF	0.140 (3.55)	0.450 (11.43)	0.228 (5.79)	0.250 (6.35)	0.003 (0.07)	15 (381)	15 (381)
56-554FF	0.140 (3.55)	0.450 (11.43)	0.228 (5.79)	0.250 (6.35)	0.002 (0.05)	15 (381)	15 (381)
81-02-14464-FFFF	0.140 (3.60)	0.440 (11.17)	0.230 (5.80)	0.250 (6.35)	0.003 (0.07)	15 (381)	15 (381)

\*Only sold in five finger lengths

Chomerics P/N	Contact Height	Width	Finger Width	Pitch	Material Thickness	Standard Length	Max Length	Mounting Surface Width	Sliding Contact Width
56-300FF	0.080 (2.03)	0.450 (11.43)	0.125 (3.18)	0.125 (3.18)	0.003 (0.08)	16 (406)	24 (610)	-	-
81-02-14289-FFFF	0.080 (2.03)	0.450 (11.43)	0.100 (2.54)	0.125 (3.18)	0.003 (0.08)	16 (406)	16 (406)	0.240 (6.10)	0.120 (3.05)
81-02-14289-FFFFSF	0.080 (2.03)	0.450 (11.43)	0.100 (2.54)	0.125 (3.18)	0.002 (0.06)	16 (406)	16 (406)	0.240 (6.10)	0.120 (3.05)
81-02-14289-FFFFST	0.080 (2.03)	0.450 (11.43)	0.100 (2.54)	0.125 (3.18)	0.002 (0.05)	16 (406)	16 (406)	0.240 (6.10)	0.120 (3.05)
81-02-14346-FFFF	0.120 (3.05)	0.600 (15.24)	0.100 (2.54)	0.125 (3.18)	0.003 (0.08)	16 (406)	16 (406)	0.320 (8.13)	0.140 (3.56)
81-02-14346-FFFFSF	0.120 (3.05)	0.600 (15.24)	0.100 (2.54)	0.125 (3.18)	0.002 (0.06)	16 (406)	16 (406)	0.320 (8.13)	0.140 (3.56)
81-02-14346-FFFFST	0.120 (3.05)	0.600 (15.24)	0.100 (2.54)	0.125 (3.18)	0.002 (0.05)	16 (406)	16 (406)	0.320 (8.13)	0.140 (3.56)
81-02-14451-FFFF	0.150 (3.81)	0.550 (13.97)	0.100 (2.54)	0.125 (3.18)	0.003 (0.08)	16 (406)	16 (406)	0.340 (8.64)	0.140 (3.56)
81-02-14451-FFFFSF	0.150 (3.81)	0.550 (13.97)	0.100 (2.54)	0.125 (3.18)	0.002 (0.06)	16 (406)	16 (406)	0.340 (8.64)	0.140 (3.56)

Chomerics P/N	Contact Height	Width	Finger Width	Pitch	Material Thickness	Standard Length	Max Length	Mounting Surface Width
81-02-11822-FFFF	0.140 (3.60)	0.370 (9.40)	0.224 (5.70)	0.252 (6.40)	0.003 (0.07)	16 (406)	20 (508)	0.220 (5.59)
81-02-11821-FFFF	0.280 (7.11)	0.600 (15.24)	0.335 (8.50)	0.375 (9.50)	0.004 (0.10)	16 (406)	20 (508)	0.290 (7.37)

Chomerics P/N	Contact Height	Width	Finger Width	Pitch	Material Thickness	Standard Length	Max Length	Mounting Surface Width
81-02-14330-FFFF	0.100 (2.54)	0.320 (8.13)	0.138 (3.51)	0.156 (3.96)	0.003 (0.08)	16 (406)	16 (406)	0.210 (5.33)
81-02-14348-FFFF	0.130 (3.30)	0.370 (9.40)	0.225 (5.72)	0.250 (6.35)	0.003 (0.08)	16 (406)	16 (406)	0.210 (5.33)
81-02-14308-FFFF	0.220 (5.59)	0.600 (15.24)	0.343 (8.71)	0.375 (9.53)	0.003 (0.08)	16 (406)	18 (457)	0.290 (7.37)

Finger Width Tolerance +/- 0.005 (0.13)      Pitch Tolerances +/- 0.005 (0.13)  
 Coil Length = 25 Feet (7.57 Meters)

# Parker Chomerics Beryllium Copper and Stainless Steel Gaskets

# Part Number and Detail Index (Sorted by Contact Height and then by Width)

## Variable (Alternating) Slot Mount Configuration and Part Number Examples: Table 37 & 38

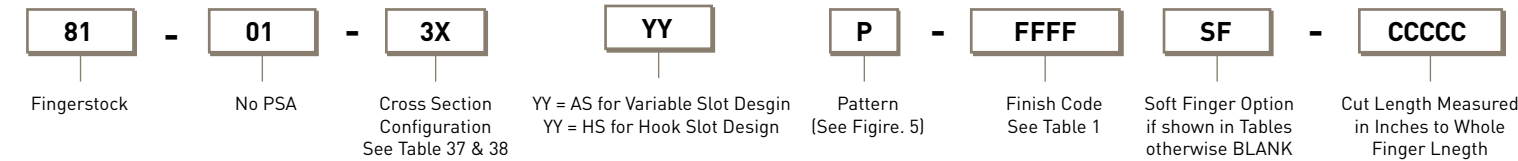

Part Number	Description
81-01-30AS1-2000	BeCu alternating slot gasket with no PSA, cross section configuration 30 (Table 37), Alternating Slot design, Pattern option 1, bright and clean finish, bulk format 17.75" length.
81-01-32AS3-4000SF-00815	BeCu alternating slot gasket with no PSA, cross section configuration 32 (Table 37), Alternating Slot design, Pattern option 3, bright nickel finish, Soft Finger option, cut to 29 whole fingers, which equates to 8.15" length.
81-01-33HS1-3000-00541	BeCu alternating slot gasket with no PSA, cross section configuration 33 (Table 38), Hook Slot design, Pattern option 1, zinc / clear trivalent chromate finish, cut to 29 whole fingers, which equates to 5.41" length.

Figure 5 - Variable (Alternating) Slot Mount, Common Patterns (Other Patterns Available)

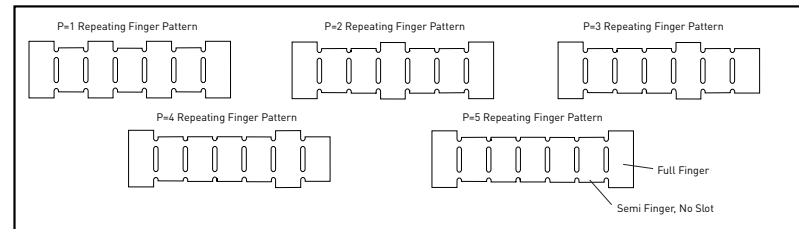
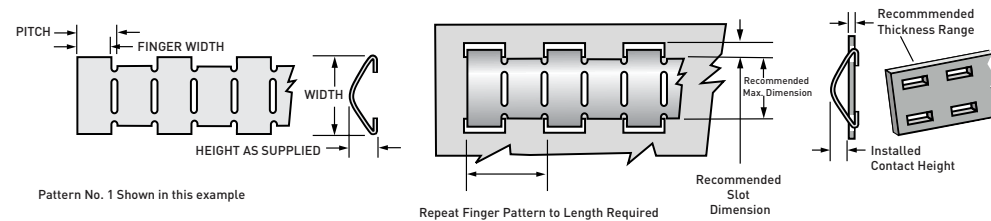

Figure 6 - Variable (Alternating) Slot Mount Configurations



Chomerics P/N	Height as Supplied	Width	Finger Width	Pitch	Material Thickness	Standard Length	Max Length	Recommended Panel Thickness Range	Recommended Slot Dimension (See Figure)	Recommended Max. Dimension (See Figure)	Installed Contact Height
81-01-30ASP-FFFF	0.110 (2.79)	0.320 (8.13)	0.169 (4.29)	0.187 (4.75)	0.003 (0.08)	18 (457)	18 (457)	0.030-0.050 (0.762-1.27)	0.095 (2.41)	0.270 (6.86)	0.070 (1.78)
81-01-30ASP-FFFFSF	0.110 (2.79)	0.320 (8.13)	0.169 (4.29)	0.187 (4.75)	0.002 (0.05)	18 (457)	18 (457)	0.030-0.050 (0.762-1.27)	0.095 (2.41)	0.270 (6.86)	0.070 (1.78)
55-740FF	0.110 (2.79)	0.320 (8.13)	0.169 (4.29)	0.187 (4.78)	0.003 (0.08)	16.3(414)	16.3(414)	--	0.095 (2.41)	0.270 (6.86)	--
56-740FF	0.110 (2.79)	0.320 (8.13)	0.169 (4.29)	0.187 (4.78)	0.002 (0.05)	16.3(414)	16.3(414)	--	0.095 (2.41)	0.270 (6.86)	--
81-01-31ASP-FFFF	0.130 (3.30)	0.370 (9.40)	0.232 (5.89)	0.250 (6.35)	0.002 (0.05)	18 (457)	18 (457)	0.030-0.050 (0.762-1.27)	0.095 (2.41)	0.320 (8.13)	0.090 (2.29)
81-01-32ASP-FFFF	0.220 (5.59)	0.600 (15.24)	0.250 (6.35)	0.282 (7.16)	0.005 (0.12)	18 (457)	18 (457)	0.060-0.070 (1.52-1.78)	0.140 (3.56)	0.520 (13.21)	0.150 (3.81)
81-01-32ASP-FFFFSF	0.220 (5.59)	0.600 (15.24)	0.250 (6.35)	0.282 (7.16)	0.003 (0.07)	18 (457)	18 (457)	0.060-0.070 (1.52-1.78)	0.140 (3.56)	0.520 (13.21)	0.150 (3.81)

\*All Symmetrical profiles are available as a slot mount.

Figure 7 - Variable (Alternating) Slot Hook On Configurations

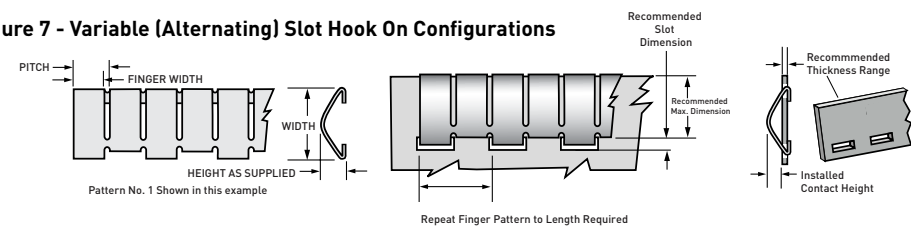

Chomerics P/N	Height as Supplied	Width	Finger Width	Pitch	Material Thickness	Standard Length	Max Length	Recommended Panel Thickness Range	Recommended Slot Dimension (See Figure)	Recommended Max. Dimension (See Figure)	Installed Contact Height
81-01-33HSP-FFFF	0.110 (2.79)	0.320 (8.13)	0.169 (4.29)	0.187 (4.75)	0.003 (0.08)	18 (457)	18 (457)	0.030-0.050 (0.762-1.27)	0.095 (2.41)	0.270 (6.86)	0.070 (1.78)
81-01-33HSP-FFFFSF	0.110 (2.79)	0.320 (8.13)	0.169 (4.29)	0.187 (4.75)	0.002 (0.05)	18 (457)	18 (457)	0.030-0.050 (0.762-1.27)	0.095 (2.41)	0.270 (6.86)	0.070 (1.78)
81-01-34HSP-FFFF	0.130 (3.30)	0.370 (9.40)	0.232 (5.89)	0.250 (6.35)	0.002 (0.05)	18 (457)	18 (457)	0.030-0.050 (0.762-1.27)	0.095 (2.41)	0.320 (8.13)	0.090 (2.29)

Note: Standard ordering length is approximately 18 in. (457mm). All standard lengths will begin and end with a full finger. Please contact Chomerics Applications Engineering Department for other panel sizes. Installed height specified in the table above is typical when installed with the range of panel widths given and with dimension D approximately at Max. Actual installed height may vary with each application.

All Dimensions: inches (mm)

Chomerics P/N	Height as Supplied	Width	Finger Width	Pitch	Material Thickness	Standard Length	Max Length	Leg Width
81-01-14413-FFFF	0.110 (2.79)	0.320 (8.13)	0.169 (4.29)	0.187 (4.75)	0.003 (0.08)	16 (406)	18 (457)	0.090 (2.29)
55-710FF	0.110 (2.79)	0.320 (8.13)	0.169 (4.29)	0.187 (4.75)	0.003 (0.08)	16 (406)	24 (610)	0.085 (2.16)
81-01-14186-FFFF	0.120 (3.05)	0.320 (8.13)	0.169 (4.29)	0.187 (4.75)	0.004 (0.10)	15 (406)	16 (406)	0.090 (2.29)
56-710FF	0.128 (3.25)	0.358 (9.09)	0.184 (4.67)	0.203 (5.13)	0.002 (0.05)	16 (406)	24 (610)	0.085 (2.16)
56-720FF	0.128 (3.25)	0.358 (9.09)	0.184 (4.67)	0.203 (5.13)	0.002 (0.05)	15.75 (400)	24 (610)	0.140 (3.56)
81-01-14215-FFFF	0.130 (3.30)	0.370 (9.40)	0.225 (5.72)	0.250 (6.35)	0.002 (0.05)	16 (406)	18 (457)	0.100 (2.54)
81-01-14309-FFFF	0.220 (5.59)	0.600 (15.24)	0.343 (8.71)	0.375 (9.53)	0.003 (0.08)	15.75(400)	15.75 (400)	0.140 (3.56)
55-720FF	0.220 (5.59)	0.600 (15.24)	0.250 (6.35)	0.282 (7.16)	0.005 (0.12)	15.75(400)	24 (610)	0.140 (3.56)

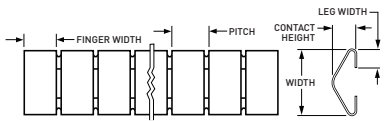

Chomerics P/N	Height as Supplied	Width	Finger Width	Pitch	Material Thickness	Length	Number of Fingers	Leg Width
81-01-14468-FFFF	0.120 (3.05)	0.320 (8.13)	0.169 (4.29)	-	0.004 (0.10)	0.169 (4.29)	1	0.085 (2.16)
81-01-14291-FFFF	0.120 (3.05)	0.320 (8.13)	0.169 (4.29)	0.187 (4.75)	0.004 (0.10)	0.730 (18.50)	4	0.085 (2.16)
81-01-14557-FFFF	0.120 (3.05)	0.320 (8.13)	0.169 (4.29)	0.187 (4.75)	0.004 (0.10)	1.478 (37.50)	8	0.085 (2.16)
55-730FF	0.128 (3.25)	0.358 (9.09)	0.184 (4.67)	0.203 (5.13)	0.002 (0.05)	0.389 (9.90)	2	0.11(2.79)
56-730FF	0.128 (3.25)	0.358 (9.09)	0.184 (4.67)	0.203 (5.13)	0.002 (0.05)	0.389 (9.90)	2	0.11(2.79)
81-01-14556-FFFF	0.190 (4.83)	0.600 (15.24)	0.187 (4.75)	-	0.005 (0.12)	0.187 (4.75)	1	0.140 (3.56)
81-01-14187-FFFF	0.220 (5.59)	0.600 (15.24)	0.250 (6.35)	-	0.005 (0.12)	0.250 (6.35)	1	0.140 (3.56)
81-01-14463-FFFF	0.220 (5.59)	0.600 (15.24)	0.250 (6.35)	0.281 (7.15)	0.005 (0.12)	7.300 (186.00)	26	0.140 (3.56)
*81-01-11835-FFFF	0.307 (7.80)	0.531 (13.50)	0.250 (6.35)	-	0.005 (0.12)	0.250 (6.35)	1	0.157 (4.00)

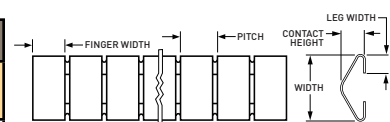

Finger Width Tolerance +/- 0.005 (0.13)  
Pitch Tolerances +/- 0.005 (0.13)  
Coil Length = 25 Feet (7.57 Meters)

# Parker Chomerics Beryllium Copper and Stainless Steel Gaskets

## Part Number and Detail Index (Sorted by Contact Height and then by Width)

All Dimensions: inches (mm)

**Table 41: Grounding Strips**

Chomerics P/N	Contact Height	Width	Finger Width	Pitch	Material Thickness	Standard Length	Max Length	Compressed Height
81-01-14359-FFFF	0.110 (2.79)	0.260 (6.60)	0.050 (1.27)	0.075 (1.91)	0.006 (0.152)	16 (406)	16 (406)	0.030 (0.76)

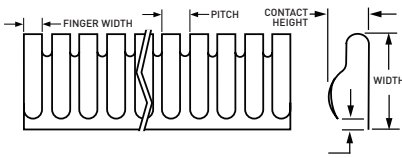

**Table 42: Grounding Contacts**

Chomerics P/N	Contact Height	Width	Finger Width	Pitch	Material Thickness	Standard Length	Max Length
55-619FF	0.080 (2.03)	0.670 (17.01)	0.141 (3.58)	0.188 (4.78)	0.004 (0.10)	16 (406)	Coil
56-619FF	0.080 (2.03)	0.670 (17.01)	0.141 (3.58)	0.188 (4.78)	0.002 (0.05)	16 (406)	Coil
55-625FF	0.080 (2.03)	0.440 (11.17)	0.141 (3.58)	0.188 (4.78)	0.004 (0.10)	16 (406)	16 (406)
56-625FF	0.080 (2.03)	0.440 (11.17)	0.141 (3.58)	0.188 (4.78)	0.002 (0.05)	16 (406)	16 (406)
55-609FF	0.100 (2.54)	0.520 (13.20)	0.141 (3.58)	0.188 (4.78)	0.004 (0.10)	16 (406)	Coil
56-609FF	0.100 (2.54)	0.520 (13.20)	0.141 (3.58)	0.188 (4.78)	0.002 (0.05)	16 (406)	Coil
55-615FF	0.100 (2.54)	0.300 (7.62)	0.141 (3.58)	0.188 (4.78)	0.004 (0.10)	16 (406)	16 (406)
56-615FF	0.100 (2.54)	0.300 (7.62)	0.141 (3.58)	0.188 (4.78)	0.002 (0.05)	16 (406)	16 (406)
55-534FF	0.120 (3.05)	0.280 (7.11)	0.357 (9.07)	0.375 (9.50)	0.003 (0.08)	24 (610)	24 (610)
56-534FF	0.120 (3.05)	0.280 (7.11)	0.357 (9.07)	0.375 (9.50)	0.002 (0.05)	24 (610)	24 (610)
55-524FF	0.150 (3.81)	0.380 (9.65)	0.228 (5.79)	0.250 (6.35)	0.003 (0.08)	16 (406)	16 (406)
56-524FF	0.150 (3.81)	0.380 (9.65)	0.228 (5.79)	0.250 (6.35)	0.002 (0.05)	16 (406)	16 (406)
55-629FF	0.205 (5.20)	0.860 (21.84)	0.141 (3.58)	0.188 (4.78)	0.004 (0.10)	16 (406)	Coil
56-629FF	0.205 (5.20)	0.860 (21.84)	0.141 (3.58)	0.188 (4.78)	0.002 (0.05)	16 (406)	Coil
55-635FF	0.210 (5.33)	0.600 (15.24)	0.141 (3.58)	0.188 (4.78)	0.004 (0.10)	16 (406)	16 (406)
56-635FF	0.210 (5.33)	0.600 (15.24)	0.141 (3.58)	0.188 (4.78)	0.002 (0.05)	16 (406)	16 (406)
55-504FF	0.235 (5.97)	0.580 (14.73)	0.343 (8.71)	0.375 (9.50)	0.003 (0.08)	24 (610)	24 (610)
56-504FF	0.235 (5.97)	0.580 (14.73)	0.343 (8.71)	0.375 (9.50)	0.002 (0.05)	24 (610)	24 (610)
55-645FF	0.255 (6.48)	1.090 (27.68)	0.335 (8.51)	0.375 (9.50)	0.004 (0.10)	16 (406)	16 (406)
56-645FF	0.255 (6.48)	1.090 (27.68)	0.335 (8.51)	0.375 (9.50)	0.002 (0.05)	16 (406)	16 (406)
55-544FF	0.270 (6.86)	0.780 (19.81)	0.148 (3.76)	0.188 (4.78)	0.003 (0.08)	16 (406)	16 (406)
56-544FF	0.270 (6.86)	0.780 (19.81)	0.148 (3.76)	0.188 (4.78)	0.002 (0.05)	16 (406)	16 (406)

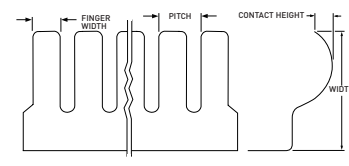
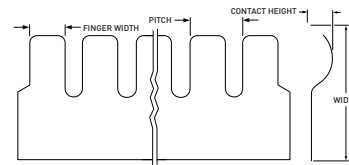
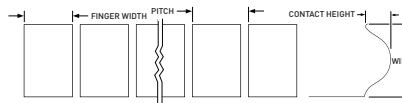

Finger Width Tolerance  
+/- 0.005 (0.13)

Pitch Tolerances  
+/- 0.005 (0.13)

Coil Length = 25 Feet (7.57 Meters)

# Metal D-Connector EMI Gaskets

Parker Chomerics' SPRING-LINE D-connector gaskets answer most shielding and grounding needs for standard connector interfaces. The gaskets are available in both high performance beryllium-copper or stainless steel. D-connector gaskets offer excellent EMI protection by ensuring that maximum surface contact is achieved via independent fingers. This will lower closure forces and provide a broad deflection range, while improving conformance to surface irregularities.

Table 43 lists all standard gasket configurations available for 9-, 15-, 25-, 37- and 50-pin connectors. Each connector standard is available with two standard cut out configurations (dimensions A and E, see Table 43 and Figure 8). Alternate cut-out configurations may be available upon request.



**Table 43: Metal D-Connector Gaskets**

FFFF	Material	A	B	C	D	E	F	G
09A1	ST	0.44 (11.18)	0.78 (19.81)	0.98 (24.89)	1.41 (35.81)	0.22 (5.59)	0.69 (17.53)	0.16 (4.06)
09A2	ST	0.35 (8.89)	0.78 (19.81)	0.98 (24.89)	1.41 (35.81)	0.18 (4.57)	0.69 (17.53)	0.16 (4.06)
09B1	BeCu	0.44 (11.18)	0.78 (19.81)	0.98 (24.89)	1.41 (35.81)	0.22 (5.59)	0.69 (17.53)	0.16 (4.06)
09B2	BeCu	0.35 (8.89)	0.78 (19.81)	0.98 (24.89)	1.41 (35.81)	0.18 (4.57)	0.69 (17.53)	0.16 (4.06)
15A1	ST	0.44 (11.18)	1.11 (28.19)	1.31 (33.27)	1.74 (44.20)	0.22 (5.59)	0.69 (17.53)	0.16 (4.06)
15A2	ST	0.35 (8.89)	1.11 (28.19)	1.31 (33.27)	1.74 (44.20)	0.18 (4.57)	0.69 (17.53)	0.16 (4.06)
15B1	BeCu	0.44 (11.18)	1.11 (28.19)	1.31 (33.27)	1.74 (44.20)	0.22 (5.59)	0.69 (17.53)	0.16 (4.06)
15B2	BeCu	0.35 (8.89)	1.11 (28.19)	1.31 (33.27)	1.74 (44.20)	0.18 (4.57)	0.69 (17.53)	0.16 (4.06)
25A1	ST	0.44 (11.18)	1.65 (41.91)	1.85 (46.99)	2.28 (57.91)	0.22 (5.59)	0.69 (17.53)	0.16 (4.06)
25A2	ST	0.35 (8.89)	1.65 (41.91)	1.85 (46.99)	2.28 (57.91)	0.18 (4.57)	0.69 (17.53)	0.16 (4.06)
25B1	BeCu	0.44 (11.18)	1.65 (41.91)	1.85 (46.99)	2.28 (57.91)	0.22 (5.59)	0.69 (17.53)	0.16 (4.06)
25B2	BeCu	0.35 (8.89)	1.65 (41.91)	1.85 (46.99)	2.28 (57.91)	0.18 (4.57)	0.69 (17.53)	0.16 (4.06)
37A1	ST	0.44 (11.18)	2.29 (58.17)	2.50 (63.50)	2.93 (74.42)	0.22 (5.59)	0.69 (17.53)	0.16 (4.06)
37A2	ST	0.35 (8.89)	2.29 (58.17)	2.50 (63.50)	2.93 (74.42)	0.18 (4.57)	0.69 (17.53)	0.16 (4.06)
37B1	BeCu	0.44 (11.18)	2.29 (58.17)	2.50 (63.50)	2.93 (74.42)	0.22 (5.59)	0.69 (17.53)	0.16 (4.06)
37B2	BeCu	0.35 (8.89)	2.29 (58.17)	2.50 (63.50)	2.93 (74.42)	0.18 (4.57)	0.69 (17.53)	0.16 (4.06)
50A1	ST	0.55 (13.97)	2.20 (55.88)	2.41 (61.21)	2.84 (72.14)	0.28 (7.11)	0.80 (20.32)	0.16 (4.06)
50A2	ST	0.45 (11.43)	2.20 (55.88)	2.41 (61.21)	2.84 (72.14)	0.23 (5.84)	0.80 (20.32)	0.16 (4.06)
50B1	BeCu	0.55 (13.97)	2.20 (55.88)	2.41 (61.21)	2.84 (72.14)	0.28 (7.11)	0.80 (20.32)	0.16 (4.06)
50B2	BeCu	0.45 (11.43)	2.20 (55.88)	2.41 (61.21)	2.84 (72.14)	0.23 (5.84)	0.80 (20.32)	0.16 (4.06)

**Figure 8**

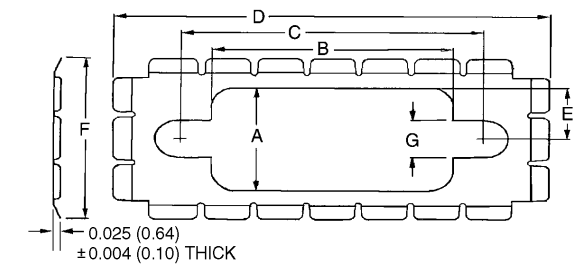

**Ordering Procedure**

Referring to Table 43, use the following part number to order D-connector gaskets.

**81 - D - XXXX - FFFF**

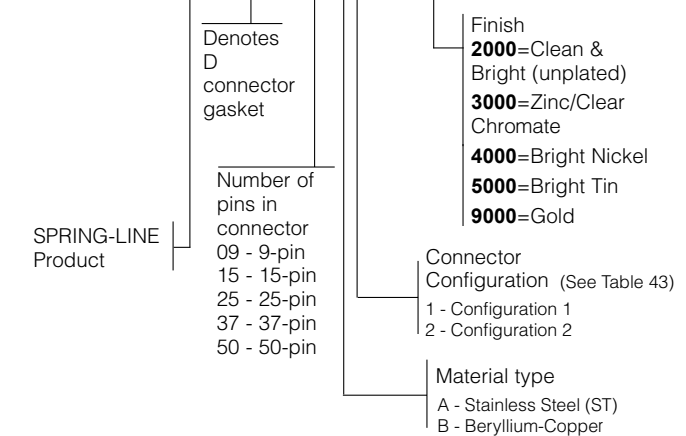

# Chomerics Worldwide

## Corporate Facilities

To Place an Order Please Contact a Customer Service Representative at the Following Locations

### North America

Division Headquarters  
Woburn, MA  
Phone +1 781-935-4850  
Fax +781-933-4318  
chomailbox@parker.com

### Europe

High Wycombe, UK  
Phone +44 1494 455400  
Fax +44 14944 55466  
chomerics\_europe@parker.com

### Asia Pacific

Hong Kong  
Phone +852 2428 8008  
Fax +852 2786 3446  
chomerics\_ap@parker.com

### Cranford, NJ

Phone +1 908-272-5500  
Fax + 1 908-272-2741

## Manufacturing Facilities

Woburn, MA; Hudson, NH; Cranford, NJ ; Millville, NJ; Fairport, NY; Grantham, UK; Saint Ouen l'Aumone, France; Beijing, Shanghai, Shenzhen, and Tianjin, China; Guadalajara and Monterrey, Mexico; Sadska, Czech Republic; Chennai, India; Selangor, Malaysia.

**[www.chomerics.com](http://www.chomerics.com)**  
**[www.parker.com/chomerics](http://www.parker.com/chomerics)**

---

*CHOMERICS and SPRING-LINE are registered trademarks of Parker Hannifin Corporation.  
© 2010 Parker Hannifin Corporation. All rights reserved.*

*Literature Number: FINGERSTOCK CAT 1003 EN September 2010 Rev A*



**ENGINEERING YOUR SUCCESS.**